



Unit 10/8-10 Adelaide Street WEST RYDE NSW

2 1 1

Offering a spacious and light filled interior, this immaculately presented unit has had all the hard work done for you and offers easy security access. This is an opportunity not to be missed and is a must to inspect this coming weekend!

Price : \$ 565,000

View : <https://www.awardgroup.com.au/sale/nsw/northern-suburbs/west-ryde/residential/unit/5230075>

Features include;

- * Spacious light filled lounge room with balcony access and quality carpets
- * Generous kitchen boasting stainless steel appliances
- * Separate dining area
- * As new stylish bathroom with separate shower and bath
- * 2 large carpeted bedrooms with a built-in robe to main
- * Lock up garage
- * Internal laundry
- * Security complex of only 15 apartments



Leighton Avery
(02) 9808 1199

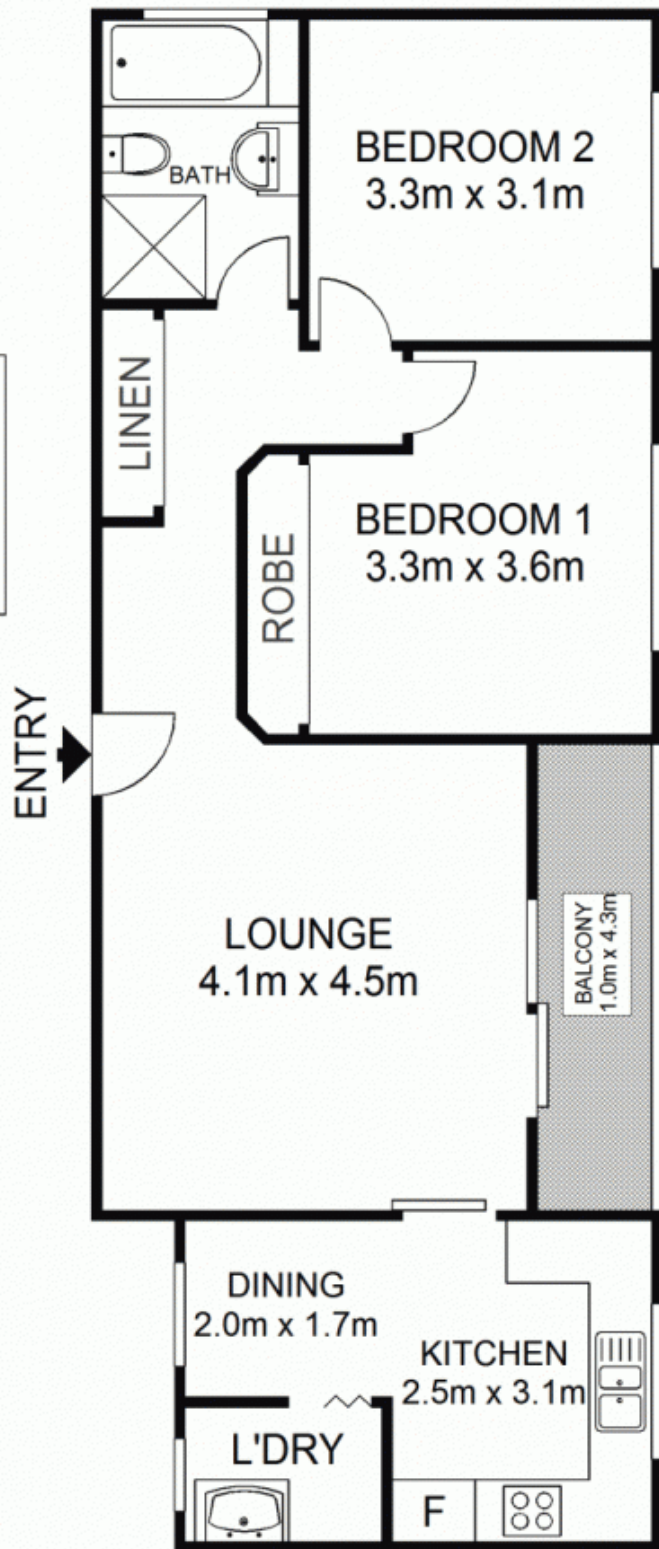
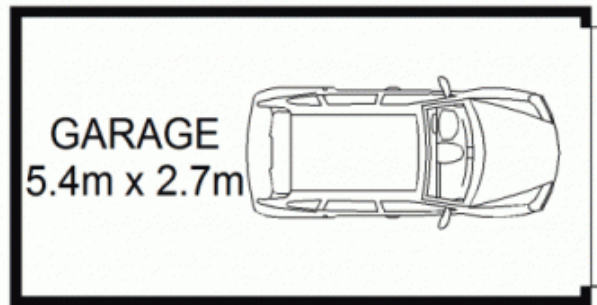

Scale shown in metres. All dimensions herein are approximate and gathered from sources believed to be reliable. Whilst every effort is made for the accuracy of our floor plans, interested parties should rely on their own enquiries. Floor Plans by Industrie Media | industriemedia.tv

S1

10/8-10 Adelaide Street, West Ryde

