

Unit 5/17 Ball Avenue EASTWOOD NSW

2 1 1

In an ideal lifestyle position, this immaculately presented full brick apartment presents a superb opportunity for effortless living/investment! It is situated in one of Sydney's most convenient and desirable suburbs and is only moments from Eastwood train station, shopping centre, parks and schools.

Land Size : 101 sqm
View : <https://www.awardgroup.com.au/sale/nsw/northern-suburbs/eastwood/residential/unit/5230166>

- * Top floor position with sunny Northern aspect
- * 2 generous bedrooms with ceiling fans and custom built-in robe to main
- * L-shaped lounge and dining area
- * Renovated kitchen with leafy outlook
- * Neat and tidy bathroom with separate shower and bath
- * Undercover entertainers balcony
- * Fresh neutral tones throughout
- * Only one common wall
- * Lock up garage



David Johnson
(02) 9808 1199

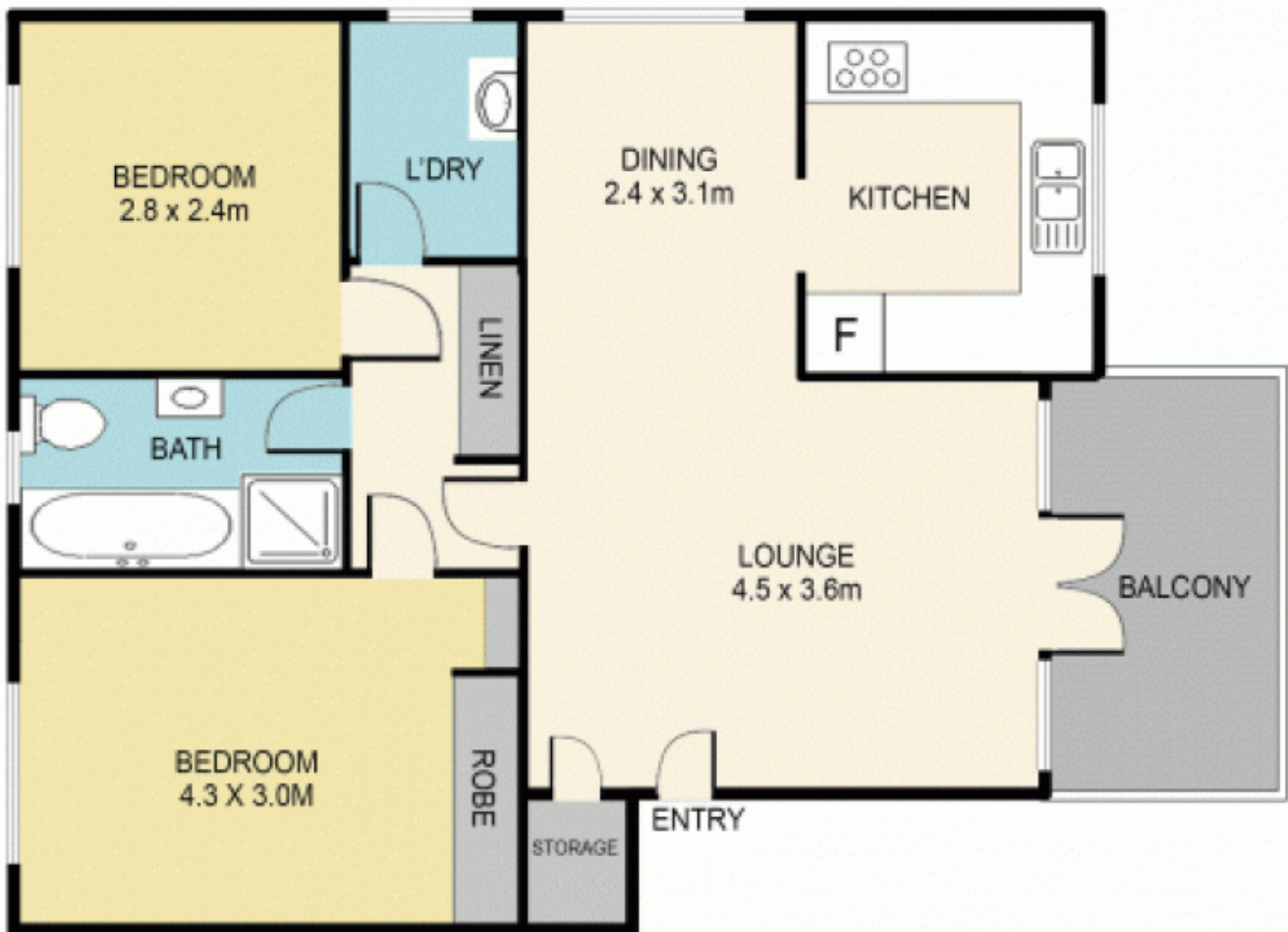
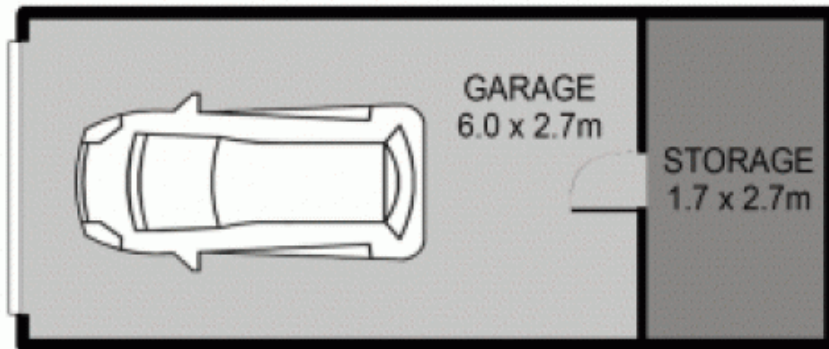

5/17 BALL AVENUE, EASTWOOD

DISCLAIMER
DIMENSIONS ARE APPROXIMATE AND SHOULD ONLY BE USED AS A GUIDE
THEY ARE NOT TO SCALE AND NO LIABILITY WILL BE ACCEPTED.